

GasPro™ TEM-200

High Flow ePTFE
In-Line Filter

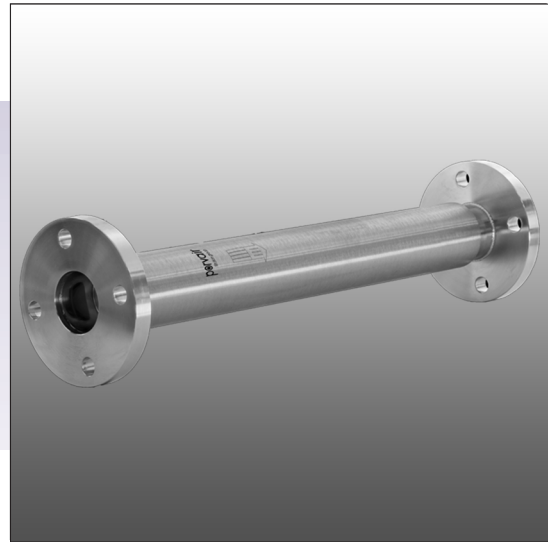

GasPro™ TEM-200 series filters are designed for 3 nm particle retention up to flow rates of 200 scfm and temperatures up to 80°C (176°F).

An ePTFE membrane (1.36 m² / 14.6 ft²) with a polypropylene support structure is enclosed within a stainless steel 316L housing for excellent flow and chemical resistance. A standard Viton® o-ring is used (other o-ring materials available on request).

Applications

- General and process inert facilities gases.
- Clean-dry air (CDA*) for critical processes including front opening unified pod (FOUP) cleaning and photolithography.

** In CDA and other facility gas filtration applications, flow, temperature, particle challenge, and other differences unique to each system, can affect overall filtration performance, and may affect the useful filtration period for each filter.*

In elevated CDA temperatures (50-69°C / 122-156°F), recommended filter change-out is one year after installation. Between 70-80°C / 158-176°F, the recommended change-out is 6 months after installation. Filter lifetime can vary due to flow, particle challenge and other differences which are unique to each system, so it is up to the user to verify product life within their system

Specifications

- **Filtration rating**
Our porous ePTFE filters provide efficient 3 nm particle retention.
- **Maximum operating temperature***
80°C (176°F).
Recommended changeout:
6 months when operating above 69°C (156°F).
- **Maximum operating pressure**
17.2 bar (250 psig) @ 20°C (68°F).
- **Maximum forward flow differential pressure**
20°C (68°F): 6.0 bar (87 psi)
80°C (176°F): 4.0 bar (58 psi)

Features and Benefits

- **Electro-polished housing**
The filter assemblies have a 15Ra electro-polished 316L stainless steel housing to prevent corrosion and particle build up on interior surfaces.
- **Out of package cleanliness**
Our GasPro™ TEM-200 filters are cleaned and packaged in a cleanroom with organic free handling for out-of-package, particle free, and chemical free cleanliness. Final assembly is purged with filtered nitrogen for initial cleanliness. Additional preconditioning is optional.
- **Multiple fitting options for ease of installation**
Standard fitting options include face/gasket seal, compression, butt weld and NPT. Special fittings, including tri-clamp (clover) sanitary and flange type, may be available upon request.
- **100% helium leak tested**
All units are tested to 1x10⁻⁹ atm cc/second.

Specifications

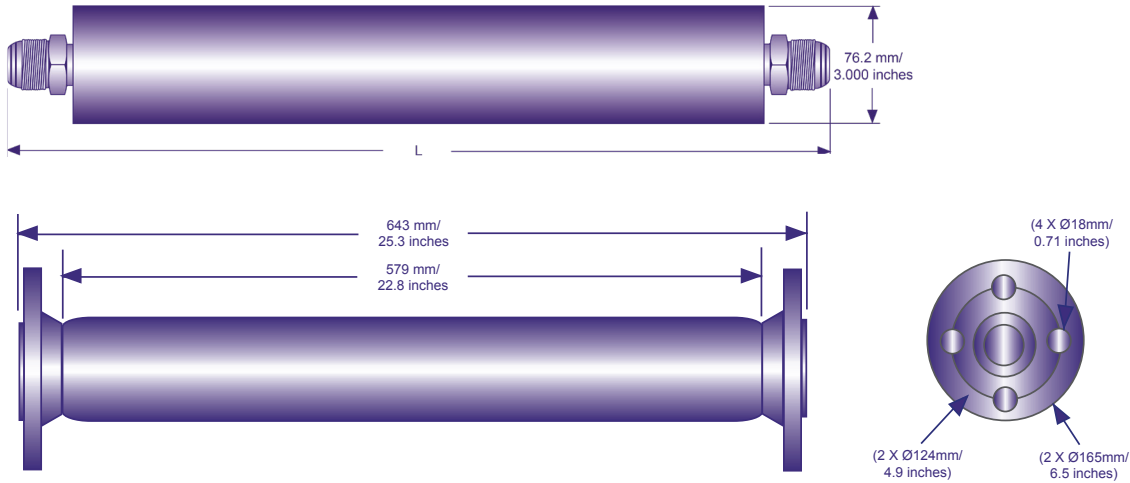

Gas flow rate / Pressure drop

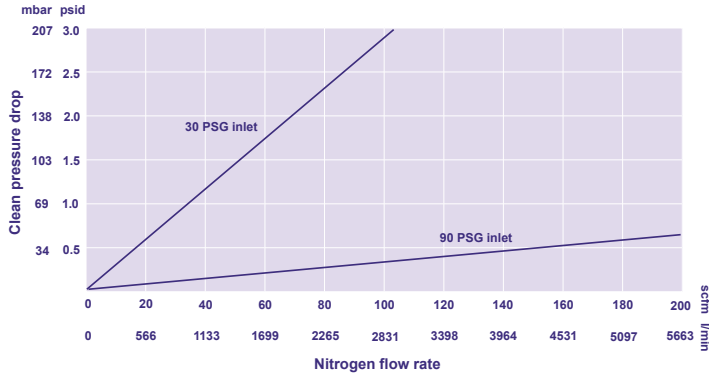

TEM-200 Part Numbers and Ordering Information

Part number	Inlet/outlet fittings	Filter media / housing	Other materials	Length (L)
TEM-215-16	1.0" male gasket seal inlet/outlet	PTFE / 316L stainless steel	Polypropylene Viton® seal*	658.4 mm (25.92")
TEM-228-16	1.0" female NPT inlet/outlet			640.1 mm (25.2")
TEM-250-24	1.5" tube stub inlet/outlet			637.5 mm (25.1")
TEM-250-32	2.0" tube stub inlet/outlet			637.5 mm (25.1")
TEM-260-DN50	Flange (see drawing for details)			643.1 mm (25.32")

* FEP encapsulated FKM O-rings are available upon request.

Not all fittings, lengths, and part numbers are shown on the chart. Please contact your Porvair representative or an approved Porvair distributor for special length and fitting options.